



OPTIONS



VERSIONS

Type	Size mm	Holding Torque Ncm	Current per Winding A	Resistance per Winding Ohm	Inductance per Winding mH	Rotor Inertia gcm ²	Length mm	Resolution %/step	Weight kg
ST6318F1004-A	63	6	1	3.8	2	16	9.6	1.8	0.095

DIMENSIONS (IN MM)

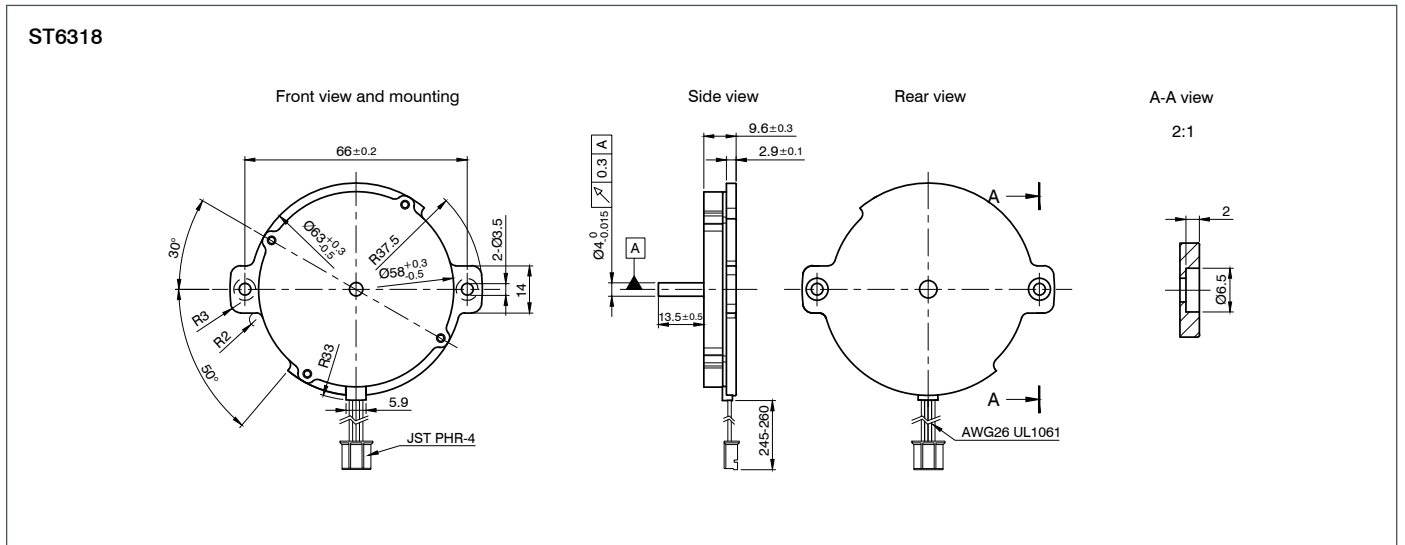

TORQUE CURVES

